

UMATIC UX1000 Underground Core Drilling Rig



Umatic UX1000 Underground Core Drill Rig

OVERVIEW:

The UX1000 is an underground type of coring drill rig for drilling medium to deep holes, capable of drilling for both surface and underground applications.

The drill is compact and modular design with flexible maneuverability for convenience to meet specific needs of operating conditions.

With the use of a hydraulic-operated positioner and a fast calibrating turntable, the drill is easy for set up and capable of drilling holes in all angles. The unique positioning mechanism requires no moving of the wireline hoist, from vertically up to vertically down.

Equipped with a robust cylinder-driven feed frame and a 75KW (optional for 90KW) power pack, this drill provides high pullback force, fast drilling penetration and quick rod-handling rate. The drill uses an electric motor (optional for diesel) to power the hydraulics on the machine.

FEATURES:

- The classic Canadian-origin 12HH chuck and rotation unit provides expectation for outstanding reliability and performance in the industry. The integrated gearbox is two-speed and fully variable-control with an independent lubrication system offering increased controllability and longer service intervals.
- The rod holder, which is fully synchronized with the chuck, is operated by a hydraulic cylinder (opening) and a long life Nitrogen spring (closing) ensuring high clamping force and quick closing action as well as improved control and decreased service needs.
- The rigid but lightweight feed frame guard prevents risks of accidents. It is easy for manual positioning at any of the several retaining points.
- The control panel is pilot-hydraulic-control design equipped with user-friendly interface and monitoring gauges. The buttons and knobs are well crafted for hand comfort and operation accuracy providing excellent ergonomic control of the rig, as well as improved safety and productivity.
- E-stop buttons on the control panel and the drill rig ensure urgent system shutoff against accidental situations.

Power unit

The standard power unit is electric, which is fit for typical underground applications. Diesel version power pack is also available according to specific application need.

Power rating	75KW/1450RPM
Main pump max flow.....	160 l/m
Main pump max pressure	300 Bar
Service pump max flow	40.5 l/m
Service pump max pressure	300 Bar
Weight	980Kg
LxWxH.....	1845x790x1380 mm

Feed frame

Feed length	1800mm, hydraulic cylinder.
Feed length.....	1800 (mm)
Feed frame length	2900 (mm)
Extension mast length.....	2000 (mm)
Feed force	89 (kN)
Pull force	89 (kN)
Feed speed.....	0.9 (m/s)

Rod holder

The rod holder is hydraulically opened and gas-pressure closed. In case of loss of hydraulic pressure the rod holder closes instantly. The gas pressure can be conveniently monitored.

Max rod size	89mm
Bore (without jaws)	102mm
Bore (without covers)	170mm
Axial holding force	45kN
Axial holding force (TC).....	90kN



Rotation unit

The rotation unit is capable of handling B-H rods with optional alternative for P rods. The rotation unit consists of a hydraulic motor, a two-speed gearbox, and a 12 HH hydraulic chuck. The chuck closes to hold the rod by hydraulic pressure, and opens to release by spring force.

Motor 107cc, Variable control
 Max rotation (rpm) 1400
 Max torque (Nm) 1275
 Spindle inner diameter (mm) 101
 Chuck axial holding force (kN) ... 150

Wireline hoist (with WL leveling device)

Capacity 1000m, 4.75mm
 Pull min 3600 N (full drum)
 Pull max 9700 N (empty drum)
 Line speed min 1.8 m/s (empty drum)
 Line speed max 4.8 m/s (full drum)

Flush pump (Optional)

Type FMC/AW 1122BCD
 Maximum flow 140 l/m
 Maximum pressure 70 Bar

Control system

The control panel is pilot-hydraulic-control design, which is compact and lightweight. The PHC control panel is equipped with user-friendly interface and monitoring gauges. The buttons and knobs are well crafted for hand comfort and operation accuracy providing excellent ergonomic control of the rig, as well as improved safety and productivity.

E-stop button is set for easy access to ensure operation safety.

Drill depth capacity

BQ 960 m
 NQ 760 m
 HQ 520 m

Rig total weight 2100Kg

Depth capacity is subject to drilling application and site conditions.

Measurements & weights

	working (mm)	Transport (mm)
A	3600	3800
B	2100	2100
C	2700	2700
D	1000	1000

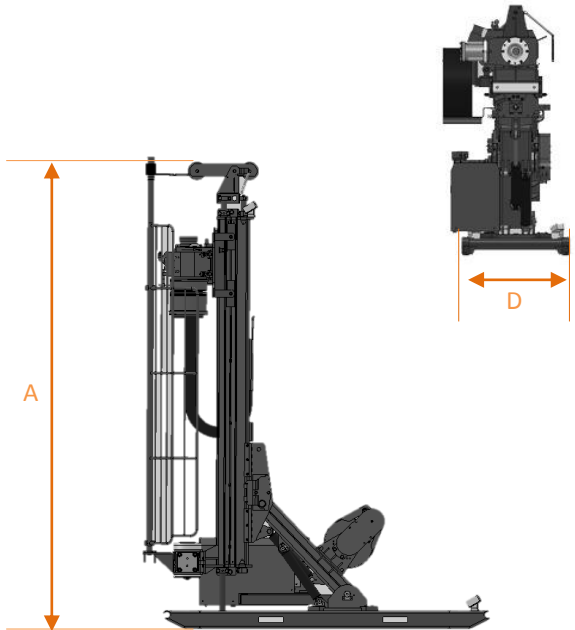
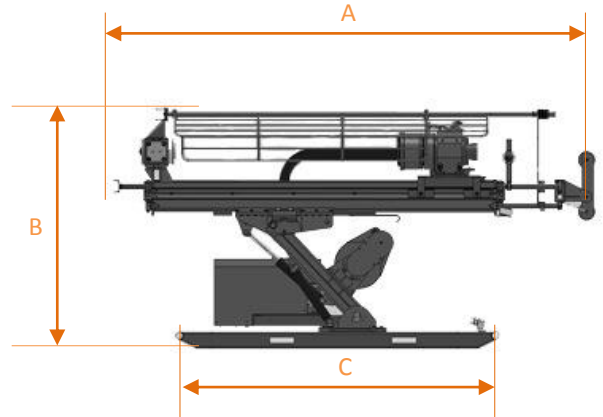



Ammeco Exploration Equipment Technology

A-1311 Jinhai Fortune Business Center, No.21 Guangqu Rd,
Beijing, China

Tel: 86-10-59574810

Fax: 86-10-59574989

www.ammeco.com

Partner of advanced drilling solutions